

Bringing an Early Solid State Transceiver into the 21st Century

Instead of replacing a basically sound transceiver, consider adding the features found in new gear.

Marc van Stralen, DK4DDS

This article describes changes I made to a Drake TR-7 transceiver to bring it up to date. Many could be applied equally well to other transceivers of the era. The Drake TR-7, a solid state HF transceiver manufactured by R. L. Drake in Miamisburg, Ohio in the late '70s into the early '80s, has remarkably good performance specifications compared to many more recent transceivers. Its double conversion architecture and analog circuitry lend itself to straightforward operation. The TR-7 is very simple to operate, has no complex menus, and is easy to service and to maintain.

I acquired some TR-7 transceivers, all in working condition, via the Internet in Germany and Holland for prices far lower than current models.

What's Not to Like?

While the basic TR-7 performance is quite good, the 30 year old design does have some disadvantages compared to modern equipment:

- The permeability tuned oscillator (PTO) that controls the operating frequency drifts more than those of modern equipment.
- The original power supply is very heavy and has the same dimensions as the TR-7 itself.
- It has no notch filter.
- The sensitivity on the higher bands is too low for quiet bands.
- The TR-7 offers neither speech processor nor DSP noise reduction.
- The two VCOs of the first oscillator circuit generate excessive phase noise.
- There is neither a

front panel TUNE button nor a KEY jack.

- Displays suffer with an analog dial and incandescent bulbs in the S-meter.
- Power output is not flat over the operating range, 1.8-30 MHz.

This article will describe how I addressed each of these deficiencies, while updating the style of the equipment. I now have a radio that can be favorably compared to modern equipment. The modifications are straightforward and incremental, so others may select which are important to them. We will take them one at a time in the sections that follow.

But Wait — There's More

There is far too much information related to this upgrade to fit in a single *QST* article. Some details are provided here, focusing on the added circuitry that might be useful in upgrading other transceivers. A more complete article as well as all PC board artwork, additional schematics and photographs are available on the *QST* binaries Web site.¹

Notch Filter

The simplest way to create a notch filter

¹ www.arrl.org/files/qst-binaries/.

for the TR-7 is to use one that operates at audio frequencies. I designed a dedicated printed circuit board (PCB) that can be mounted on the underside of the parent board of the TR-7 with two small stand-off insulators, the type normally used for PC serial and USB ports. The filter is controlled by a relay.

Only a small potentiometer has to be installed at the front of the TR-7 to control the notch filter. When the potentiometer is turned fully counterclockwise, the notch filter will be off. Table 1 lists the defined specifications. The notch filter installed in the TR-7 is shown in Figure 1 with the schematic and parts list in Figure 2.

DSP Noise Reduction

Most current transceivers offer digital signal processing (DSP) noise reduction. As with the notch filter, I chose an audio frequency DSP to provide this function. I used a modified NES-5 DSP board from BHI in the UK (www.bhinstrumentation.co.uk). There are other products that could also be employed, however.

The NES-5 DSP noise reduction unit is intended to be connected to the loudspeaker

output of a receiver or transceiver. It is built into a small enclosure and includes a built in speaker amplifier IC. I modified the unit by opening the enclosure and removing the PCB. I unsoldered the LM380, the 12 V regulator IC, input resistors R1 and R2, and also the output resistors R7 and R8. I replaced the resistors with two 10 turn/50 k Ω potentiometers as shown in Figure 3. Mount the DSP board

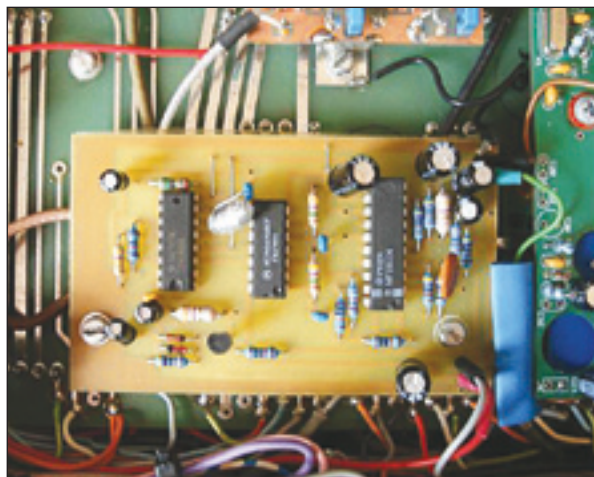

Figure 1 — Notch filter PCB assembled on to the parent board of the TR-7.

Table 1
Specifications of
Added Notch Filter

Notch Frequency	Notch Depth
300 Hz	30 dB
500 Hz	35 dB
1000 Hz	42 dB
2000 Hz	45 dB

Table 2
Component Changes
in TR-7 Exciter Section

Part	New Value
C307	47 nF
C310	220 nF
R330	3300 Ω
R333	470 Ω

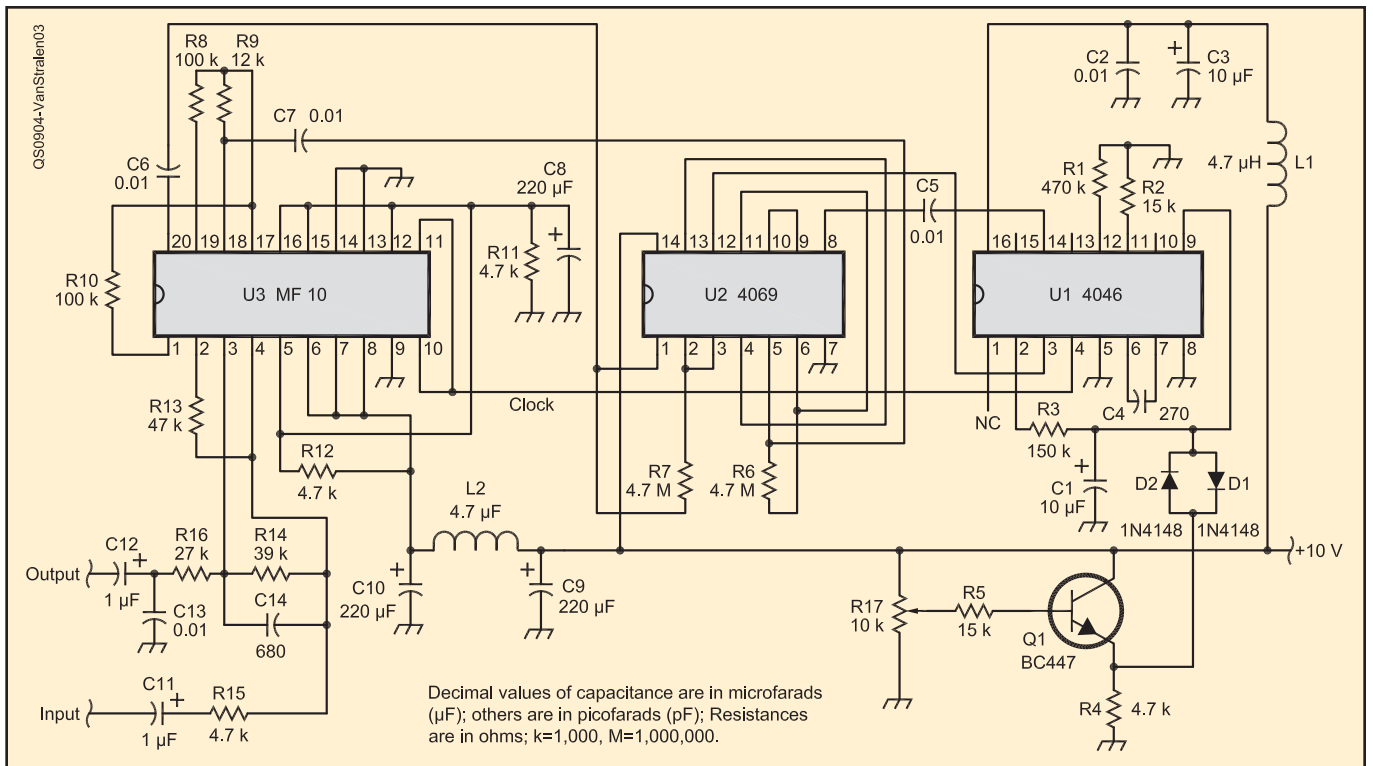

Figure 2 — Notch filter schematic diagram and parts list.

- C1 — 10 μF , 16 V electrolytic capacitor.
- C2, C5-C7, C13 — 10 nF ceramic capacitor.
- C3 — 10 μF , 16 V electrolytic capacitor.
- C4 — 270 pF, 2% capacitor.
- C8-C10 — 220 μF , 16 V, 3.5 mm electrolytic capacitor.
- C11, C12 — 1 μF , 16 V electrolytic capacitor.
- C14 — 680 pF ceramic capacitor.
- D1-D3 — 1N4148 silicon diode.
- L1, L2 — 4.7 μH SMMC RFC.
- Q1 — BC 547 transistor.
- R1 — 470 k Ω , $\frac{1}{8}$ W resistor.
- R2 — 15 k Ω , $\frac{1}{8}$ W resistor.
- R3 — 150 k Ω , $\frac{1}{8}$ W resistor.
- R4, R11, R12, R16 — 4.7 k Ω , $\frac{1}{8}$ W resistor.
- R5 — 15 k Ω , $\frac{1}{8}$ W resistor.
- R6, R7 — 4.7 M Ω , $\frac{1}{8}$ W resistor.
- R8, R10 — 100 k Ω , $\frac{1}{8}$ W resistor.
- R9 — 12 k Ω , $\frac{1}{8}$ W resistor.
- R13 — 47 k Ω , $\frac{1}{8}$ W resistor.
- R14 — 39 k Ω , $\frac{1}{8}$ W resistor.
- R15 — 27 k Ω , $\frac{1}{8}$ W resistor.
- R17 — 10 k Ω linear potentiometer.
- U1 — HEF 4046.
- U2 — HEF 4069.
- U3 — MF 10.

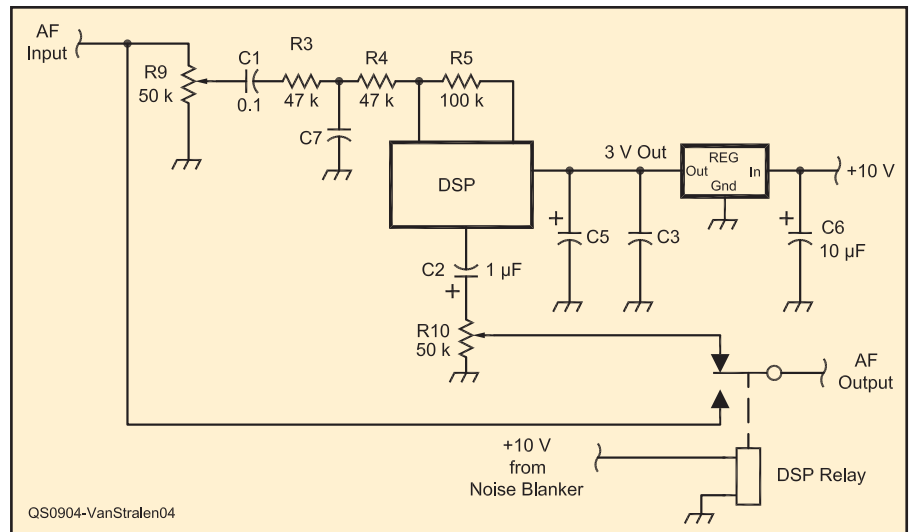

Figure 3 — Schematic of modified DSP including control circuitry.

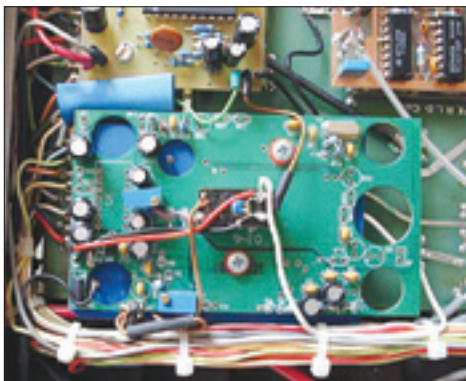

Figure 4 — DSP mounted on the underside of the TR-7 parent board.

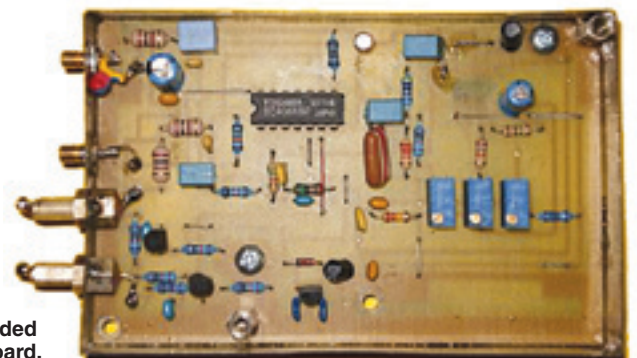

Figure 5 — Added speech processor board.

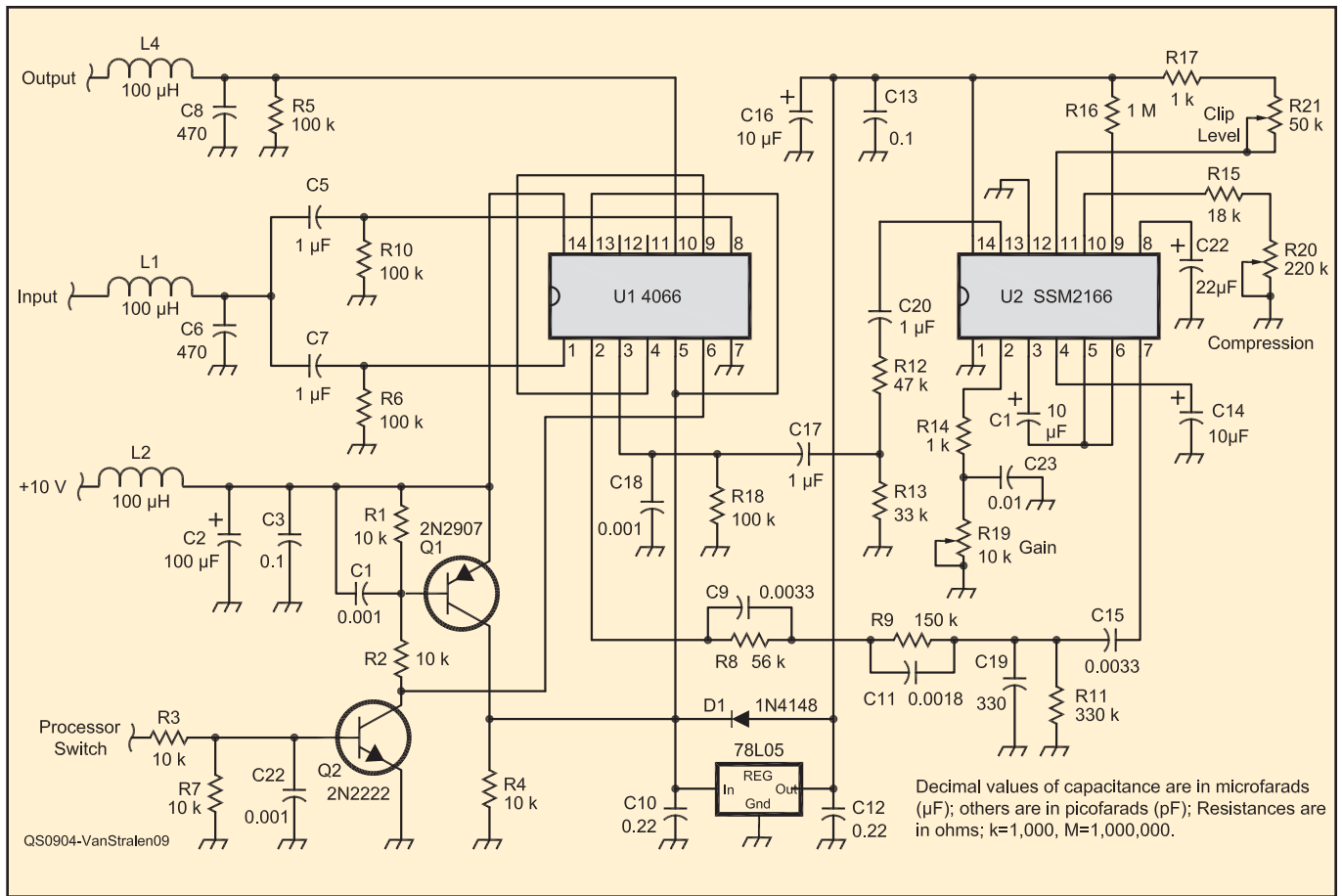

Figure 6 — Schematic diagram and parts list of speech processor board.

- C1 — 1 nF ceramic capacitor.
- C2 — 100 µF, 16 V electrolytic capacitor.
- C3, C13 — 100 nF ceramic capacitor.
- C4, C18 — 1 nF ceramic capacitor.
- C6 — 470 pF ceramic capacitor.
- C5, C7, C17, C20 — 1 µF foil capacitor.
- C8, C18 — 1 nF ceramic capacitor.
- C9, C15 — 3.3 nF ceramic capacitor.
- C10 — 220 nF ceramic capacitor.
- C11 — 1.8 nF ceramic capacitor.
- C12 — 220 nF ceramic capacitor.
- C14, C16, C21 — 10 µF, 16 V electrolytic capacitor.

- C19 — 330 pF ceramic capacitor.
- C22 — 22 µF, 16 V electrolytic capacitor.
- C23 — 10 nF ceramic capacitor.
- D1 — 1N4148 silicon diode.
- L1-L4 — 100 µH SMMC RFC.
- Q1 — 2N2907 PNP transistor.
- Q2 — 2N2222 NPN transistor.
- Q3 — 78L05 voltage regulator IC.
- R1-R4, R7 — 10 kΩ, ½ W resistor.
- R5, R6, R10, R18 — 100 kΩ, ½ W resistor.
- R8 — 56 kΩ, ½ W resistor.
- R9 — 150 kΩ, ½ W resistor.

- R11 — 330 kΩ, ½ W resistor.
- R12 — 47 kΩ, ½ W resistor.
- R13 — 33 kΩ, ½ W resistor.
- R14, R17 — 1 kΩ, ½ W resistor.
- R15 — 18 kΩ, ½ W resistor.
- R16 — 1 MΩ, ½ W resistor.
- R19 — 10 kΩ trimming potentiometer.
- R20 — 220 kΩ trimming potentiometer.
- R21 — 50 kΩ trimming potentiometer.
- U1 — 4066.
- U2 — SSM2166.



Figure 7 — Installed front panel extension, as seen from the bottom.



Figure 8 — TR-7 with rear extension installed.



Figure 9 — LED built into base of dial light bulb.

and a small 10 V reed relay on an empty piece of PCB board material so that the whole assembly can be mounted on the underside of the parent board as shown in Figure 4.

Speech Processor

The speech processor is a design of Ulrich Graf, DK4SX, who also used it for his modified TR-7. The processor is based on the SSM2166 IC from Analog Devices (www.analog.com). I designed a dedicated single sided PCB for the speech processor, to allow it to fit on the underside of the parent board. Some small modifications of the exciter board are needed to switch the processor on or off. The whole unit was built in a complete enclosed metal box, as shown in Figure 5 with the schematic and parts list provided in Figure 6.

Mechanical Changes

The original TR-7 envelope does not

provide much space to integrate additional electronics or circuit boards. The only places are on the underside on the parent board and a little space in the high pass filter compartment. There is also very little additional front panel real estate for additional switches or controls. I decided to increase the transceiver and front panel height by about 5/8 inch to accommodate additional jacks and control functions. The changes are shown in Figures 7 and 8.

Bulbs Replaced by LEDs

The bulbs of the S-meter, all indicator lights and the analog dial light are replaced by high intensity LEDs. I used simple defective bulbs, removed the glass and internal wiring and soldered a resistor and LED into the bulb base as shown in Figure 9. By using this method you don't need to replace the sockets in the transceiver.

Conclusions

The additions and changes to the TR-7 that I have described add the modern conveniences we have come to expect to a radio that has been around for more than a quarter century (see Figure 10). The result is a radio

that is fun to operate and a good performer in any time period.

Marc van Stralen, DK4DDS, has been licensed since 1970 at age 18 first as PA0MJY, later as PA1HFO. He received his present call letters on his move to Germany in 2004.

Marc has studied electronics and telecommunications and had his own business refurbishing and selling used electronic manufacturing equipment such as soldering machines and placement equipment. Marc retired in 2008.

His interest in electricity and electronics started early and when he was 3 years old he could screw connectors on to electrical wire. At 12 he made his first attempt at building radios, starting with a germanium diode crystal set.

His first Amateur Radio project was the construction of fully transistorized (solid state) 10 W, 2 meter SSB transceiver. After earning his A license, he focused on HF homebrew and kit radios.

You can reach Marc at Schulstrasse 21, D-48455, Bad Bentheim, Germany or at dk4dds@t-online.de.

**Did you enjoy this article?
Cast your vote at:**

VOTE www.arrl.org/members-only/qstvot.html

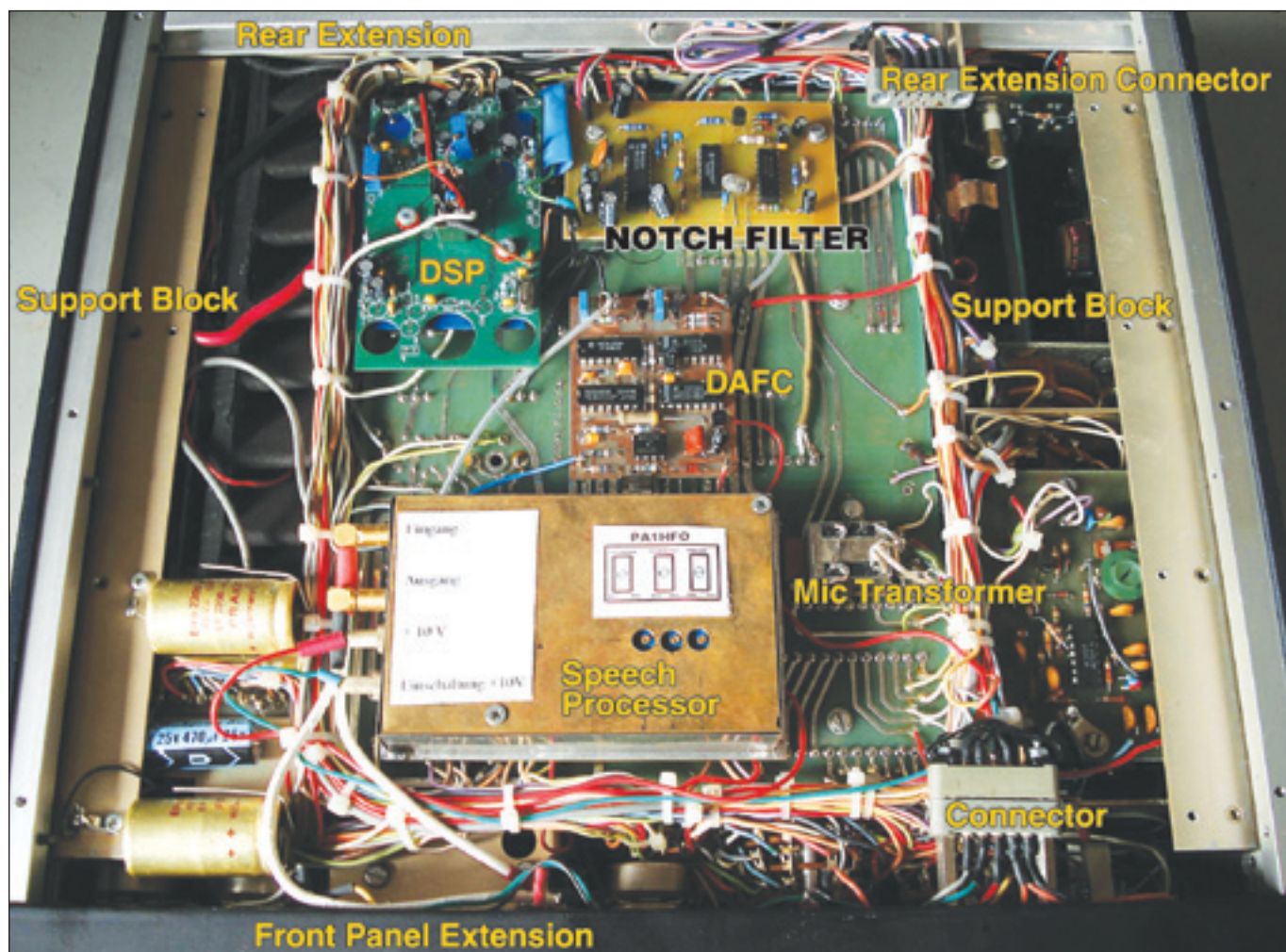

Figure 10 — Bottom view of the TR-7 showing modifications installed.